

R.296 Track Cleaning Coach

Model Railway Track quickly becomes dirty especially if it is used in the loft or the garden shed. If the Hornby Track Cleaning Coach is used regularly though, the track surface will remain clean giving the optimum running conditions for locomotives and rolling stock. When not in use, it is of suitable appearance to stand in a station siding without looking out of place.

On the underside of the Coach are two running blocks and these are spring loaded to maintain pressure on the rails. Abrasive strips, which are self-adhesive, are supplied and after removing the backing paper, two of these should be fixed to the bottom surface of the running blocks (*diag. 1*). It is important to fit the abrasive strips to the blocks centrally giving an equal amount of wrap round each end. The strips are made of a light abrasive and will not remove the protective coating of the rails.

After a period of time, the abrasive will wear and become ineffective. For this reason spare strips are supplied.

Once the abrasive strips have been fixed to the running blocks, the Coach can be placed on the track. There is a certain amount of friction between the abrasive strips and the track, therefore it is possible that an 0-4-0 engine will not have enough power to drive the Coach around the track.

An 0-6-0 or larger locomotive can be used and it is preferable to push rather than pull the Coach along the track, as a better cleaning action is obtained (*diag. 2*).

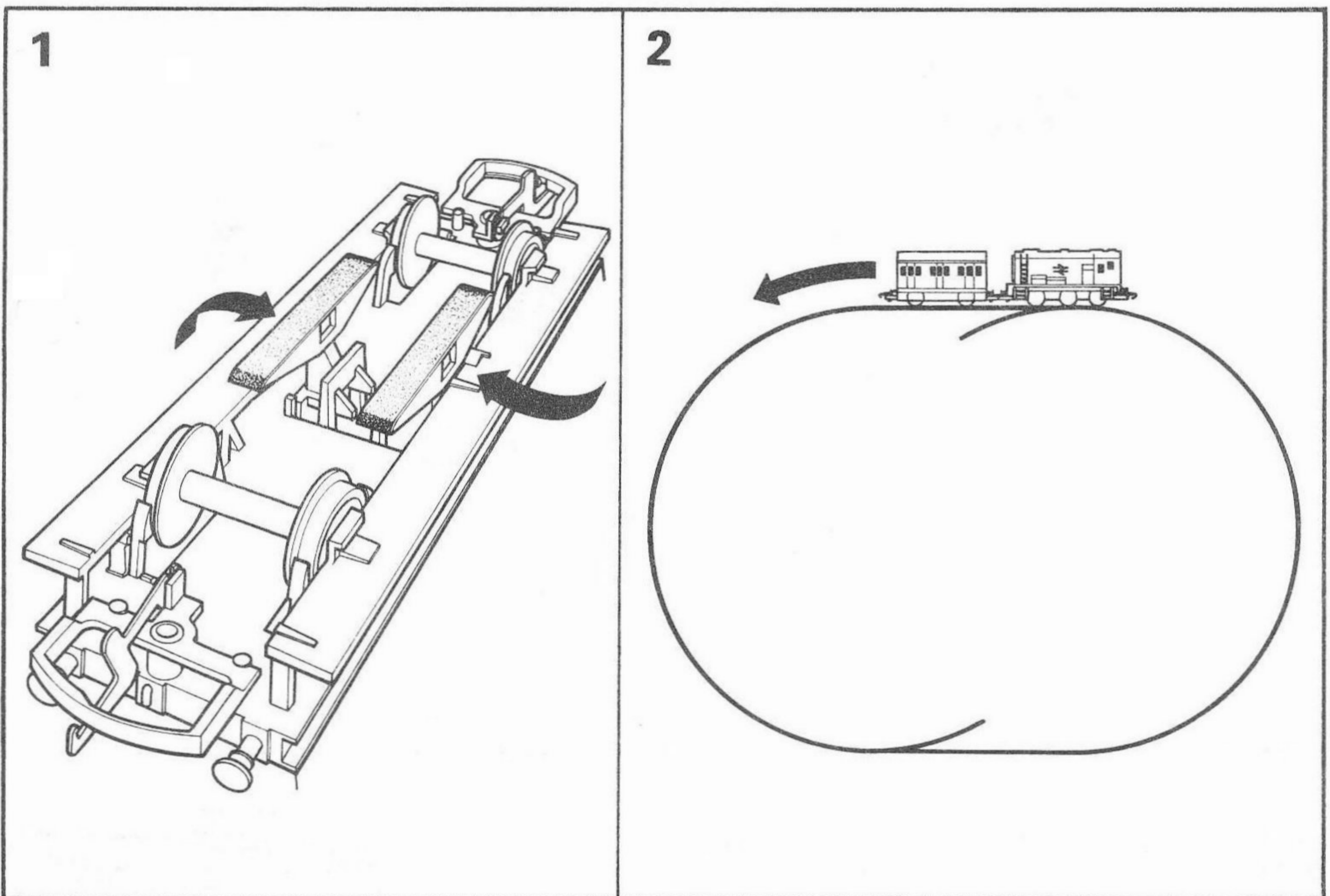

The Track Cleaning Coach will not remove such things as smoke oil from the track. If smoke oil or similar substances are spilled on the rails, they should be wiped off with a rag.

If, in the course of time, the pressure of the running blocks on the rails becomes too slack, it can be adjusted by removing the roof of the Coach and altering the tension of the metal strip (*diag. 3*). Only a small adjustment will be required. If the metal strip is over bent it will lift the vehicle off the track.

The roof is removed by carefully pushing the base of the windows in and gently levering with a screwdriver (*diag. 4*).

Spare adhesive strips, part number M.1319, can be obtained from the Hornby Service Department.

3

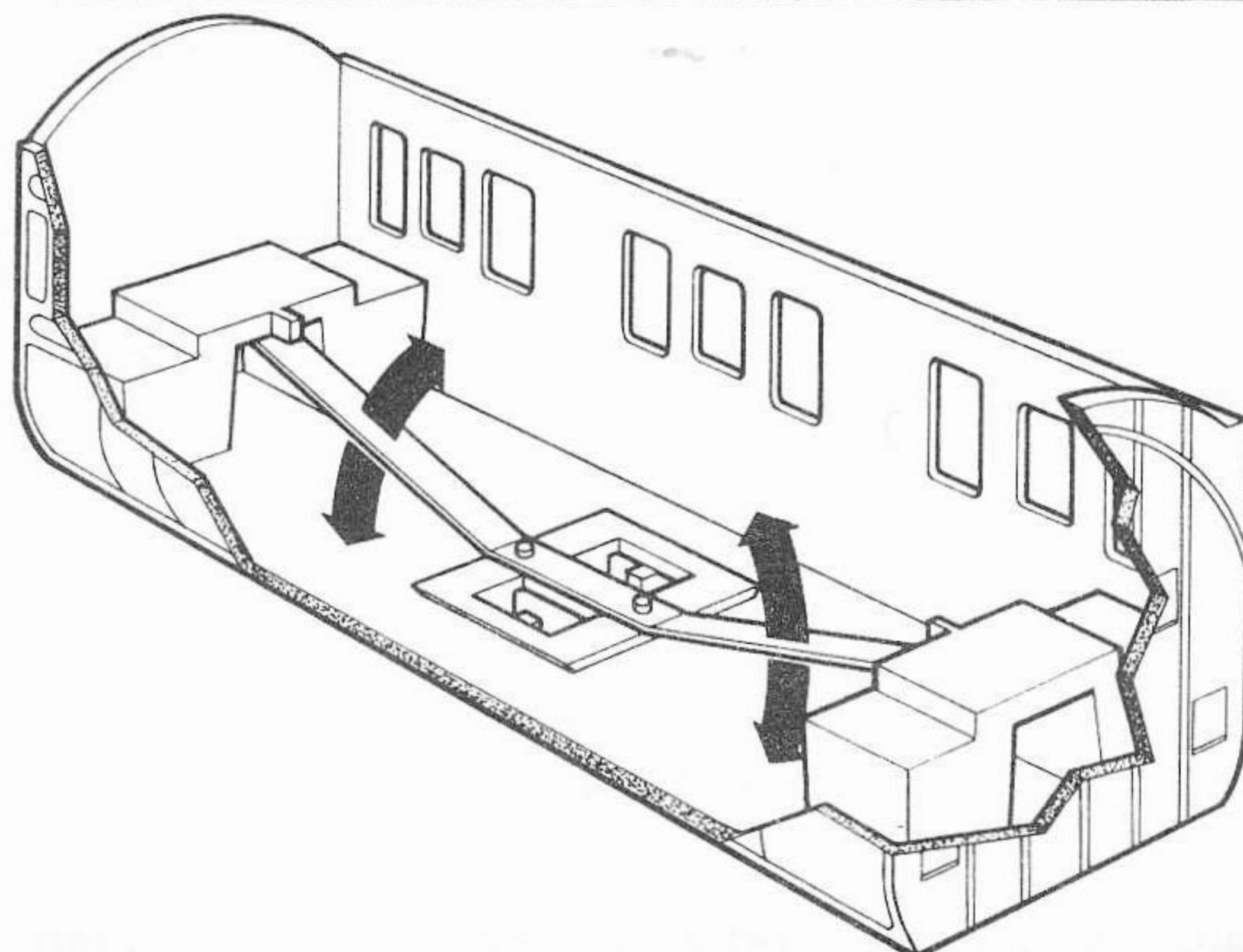

4

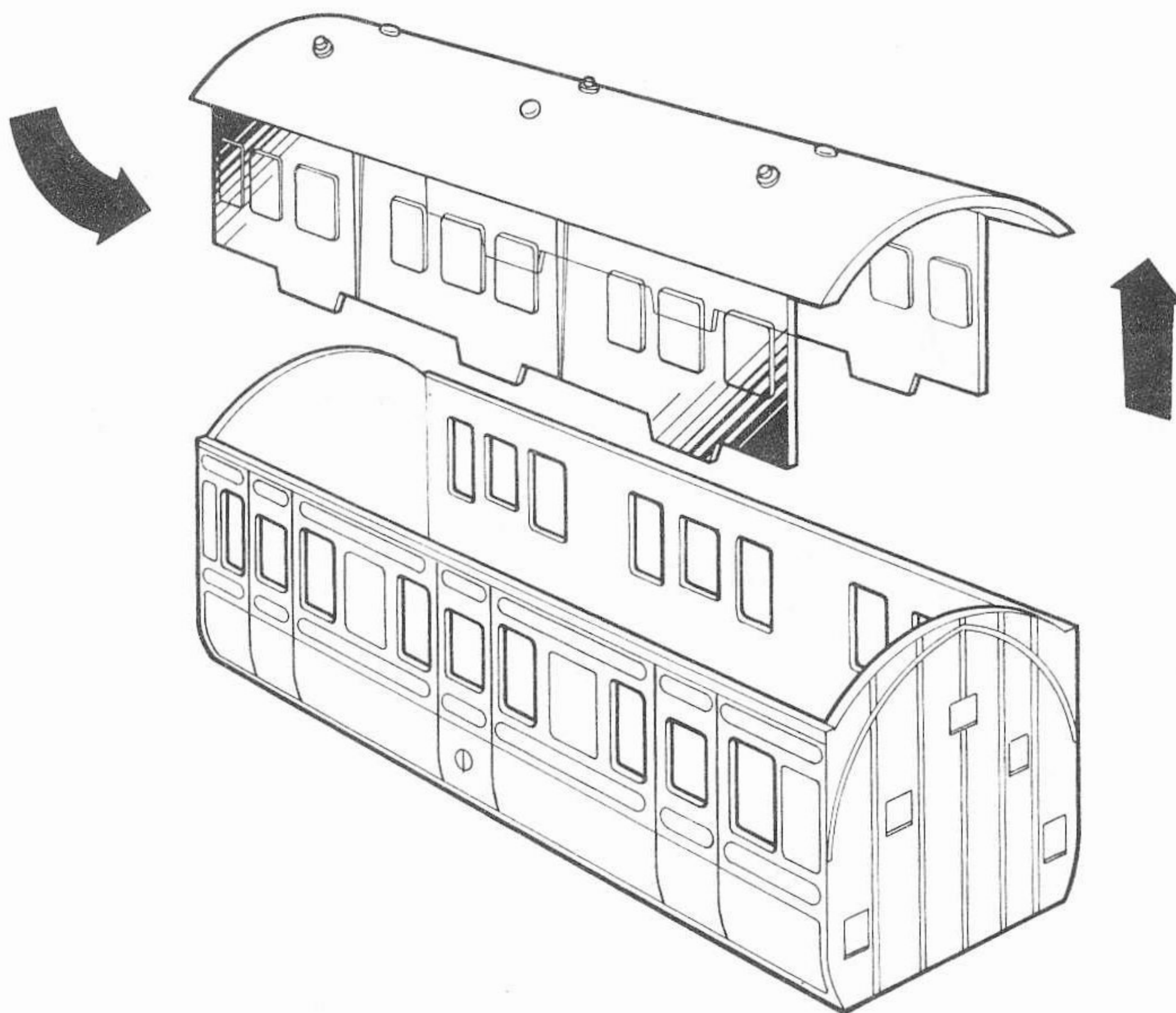

Enquiries regarding spares and service should be addressed to:
Hornby Service Centre, Westwood, Margate, Kent, CT9 4HZ, England.

Made in Great Britain by

HORNBY HOBBIES