

Lubrication – Although the locomotive was lubricated during manufacture, the lubricant can sometimes dry out in storage. Lubrication should be carried out at approximately 6-monthly intervals, or every 100 hours of running. Instructions for carrying out lubrication procedures are given in section 1 on pages 2 and 3.

Locomotive Bodywork – The locomotive body is overall spray painted and the rest of the decoration is applied by a printed process, not transfers.

Spare Parts and Service

Spare parts packs can be obtained from Hornby Service Dealers who are also able to offer a repair service.

Television Suppression

Your Hornby locomotive incorporates radio and television interference suppressors. Should interference be experienced despite these precautions, it may be due to close proximity of the model railway layout to receivers, aerials, or their 'downlines'. In this case, move the layout further away from aerials and receivers. **It is most important that track and wheels be kept absolutely clean.**

Safety Notes

- This locomotive is not suitable for children under 3 years of age because of small parts which can present a choking hazard. Some components have functional sharp points and edges – handle with care.
- This locomotive is intended for indoor use only.
- The transformer is not a toy. It is a 'Transformer for Toys'. Before use, check that the transformer is the correct voltage for your mains electricity supply. This locomotive is only to be used with the recommended transformer. The transformer should be examined regularly for damage to the casing, plug pins and cables.

In the event of such damage, the set should not be used until the transformer is replaced with a new Hornby recommended unit. Never attempt to open the transformer yourself.

- This locomotive must not be connected to more than the recommended number of power supplies. The output terminals of the transformer must not be connected directly, or indirectly, to the output of any other AC circuit derived from a transformer or mains power supply.
- Before cleaning any part, disconnect the transformer from the mains electricity supply. **Do not use liquid for cleaning.**
- Please retain these details and address for future reference.

IMPORTANT

- **Only remove the locomotive from the packaging by carefully pushing through the finger holes below and carefully lifting.**
- **This locomotive is made to exacting fine scale standards and therefore necessarily incorporates small, delicate, protruding parts – handle with care.**
- **Before using the model, read through the Operating and Maintenance Instructions in this leaflet.**



12V-15V



Waste electrical products should not be disposed of with household waste. Please recycle where facilities exist. Check with your Local Authority or retailer for advice

LOCOMOTIVES WITH TYPE M MOTOR

0-6-0 Steam, Diesel & Electric Locomotives

Operating and Maintenance Instructions

General

Please read right through these instructions, particularly the Safety Notes on page 4.

Hornby locomotives are precision built and, if treated with care, will give many years of good service. Care should be taken to avoid damage when handling the model.

The electric motor of the locomotive is designed to be operated from a variable 12 volts, DC power supply only. This should be obtained by using a suitable Power Controller operated from the normal domestic mains domestic mains electricity supply.

NEVER CONNECT A LOCOMOTIVE DIRECTLY TO THE MAINS ELECTRICITY SUPPLY.

The locomotive will normally draw a current of between .2 and .4 amp depending upon the track configuration and whether or not gradients are included. There will be a current surge on starting the locomotive.

DCC Ready

Contact your specialist dealer for advice.

Running Hints

If a locomotive ceases to respond normally to the power controller, or runs badly, check that the following are in order:

- All electrical connections are correctly made and the wall power socket is switched 'ON'.
- The power is connected correctly to the power track.
- All track sections are correctly fitted together and all fishplates (rail-joiners) are fitting tightly onto adjoining metal rails.
- All locomotive wheels are correctly positioned on the track rails.
- The direction control switch on the train controller is set to operate in one direction or the other, and not in the central 'OFF' position.

Routine Maintenance

Track Cleaning – In normal use, model railway layouts will eventually accumulate a blackish deposit on the running surfaces of the rails, and some of this will be transferred onto the locomotive's pick-up wheels.

The 12 volt DC supply is collected from the track through the wheels on one side of the locomotive and returned through the wheels on the other side. If the deposit is allowed to build up, it will have the following adverse effects:

- The driving wheels will not be able to achieve maximum traction
- There will be a reduction in the power reaching the locomotive motor

It is therefore essential that the track, **and wheels**, are kept clean. This can be done by wiping the surfaces with a clean, non-fluffy cloth. More stubborn deposits can be removed by using the Hornby Track Cleaning Rubber, reference R8087, which can be obtained from Hornby Service Dealers.

Motor – After approximately 100 hours of running time, the non-replaceable carbon brushes in the motor of your locomotive may have become worn out. This will result in the locomotive's speed being reduced or it not responding to the train controller. If this happens, it will be necessary for the motor to be replaced and this work should be carried out by a Hornby Service Dealer. Instructions for replacing the locomotive motor are given on pages 2 and 3 of this leaflet, only for owners who have experience in such tasks and who have soldering facilities. Spare motor assemblies are available from Hornby Service Dealers.

Chassis – The locomotive chassis may, from time to time, pick up fluff, fabric fibres and pet hairs which can become entangled in the gears and around axles. For this reason, it is not advisable to run the locomotive on track which is laid on a carpet. It is important to check regularly and remove any such debris with the aid of small tweezers.

1 Lubrication

IMPORTANT – Only apply small single drops of light machine oil to the places indicated in red in Fig.2. This is best achieved by making a simple oil ‘dropper’ as illustrated in Fig. 1. Insert a straightened paper clip into a cork and use a bottle cap as a container for the oil. A small drop of oil can then be picked up by the dropper and applied in exactly the right place. Immediately wipe off any excess oil, especially from the locomotive body. Only lubricate moving parts.

Fig.1

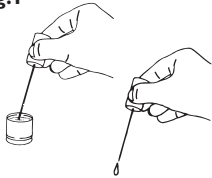
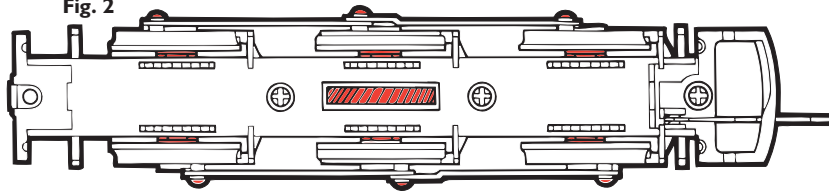

Fig. 2



3 Removing the motor assembly

Unscrew the motor assembly retaining screw ‘D’, and washer ‘F’, and carefully lift out the complete assembly, from the front, until the clips ‘E’, (See Fig.8), are released from the chassis. **Caution:** Take care to avoid distorting the copper-coloured pick up contacts ‘H’ as the ends emerge from behind the front and rear wheels (Fig.7). A complete motor replacement assembly should be fitted. These are available from Official Hornby Service Dealers.

Fig.7

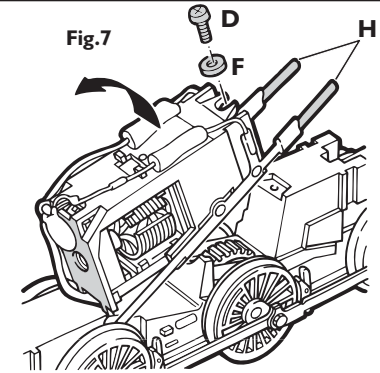

2 Body Removal

Detach the rear coupling unit, at the coal bunker end, by removing screw ‘A’ as shown in Fig.3. Release chassis by inserting a flat-bladed screw-driver between the chassis and inside rear of the locomotive body and gently disengaging the chassis clip from the body (Fig.4). Carefully lower this end of the chassis until the whole chassis can be removed from the body.

Fig.3

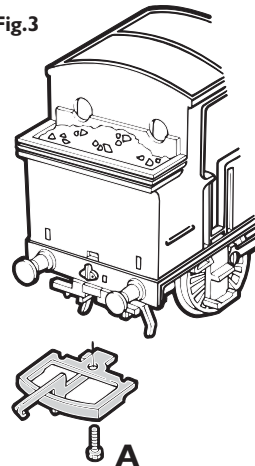
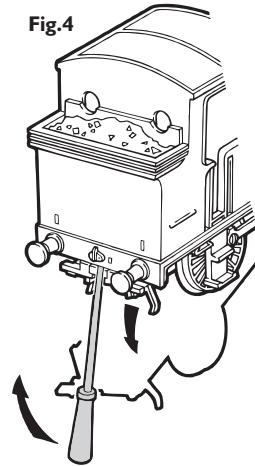

Fig.4



If your locomotive is a diesel shunter, the body is fitted onto the chassis the other way round (Fig.5). In this case, the front coupling, at the radiator end, has to be removed (see fig.3). The diesel shunter also has a plastic body spacer ‘B’ into which the chassis clips ‘C’ fit at the cab end of the locomotive as shown in Fig.6.

Fig.5

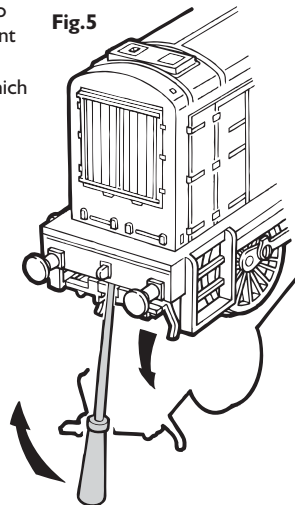
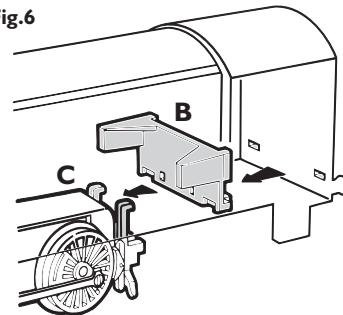

Fig.6



5 Replacing the locomotive body

Locate the chassis clips ‘C’ into position in the body (Fig.9), and hinge up chassis until clip ‘J’ (see Fig.8 above) snaps into its position in the locomotive body. In the case of the diesel shunter, firstly clip the body spacer ‘B’ into position in the body and then fit chassis clips ‘C’ into the body spacer, before clipping the chassis up into the body (Fig.10). Refit the coupling assembly with screw ‘A’ as illustrated in Fig.3.

Fig.9

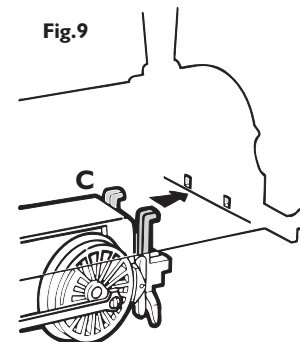

Fig.10

