

## OO/HO GENERAL SPARES – IA

with Mk. 3 Couplings produced from 1st January, 1959

X.328

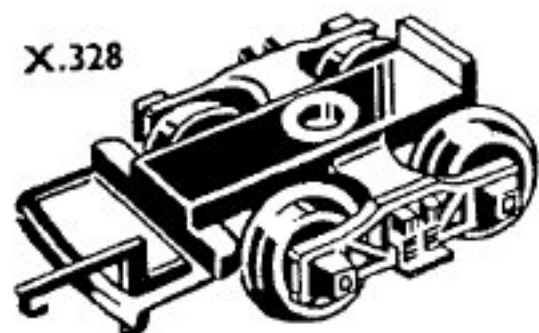

X.311

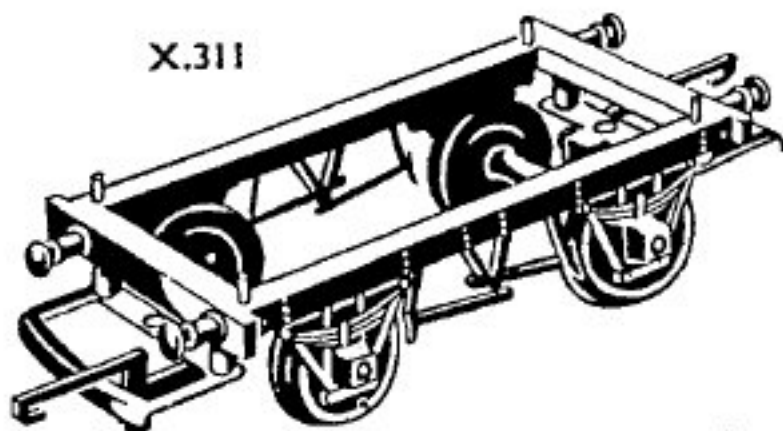

X.3109

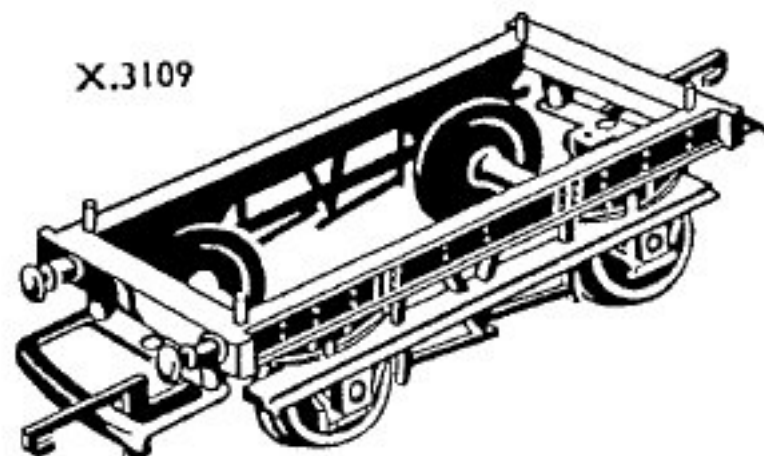

X.310

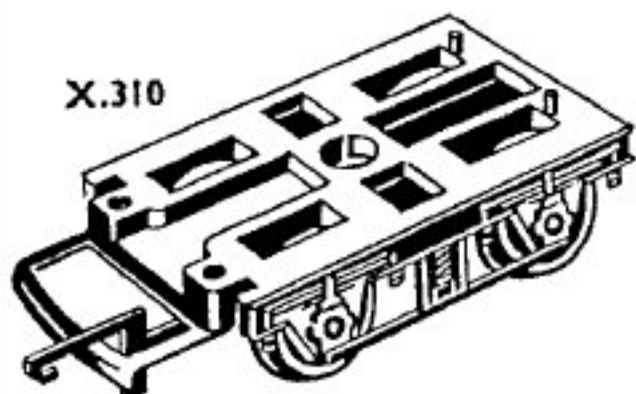

X.3168

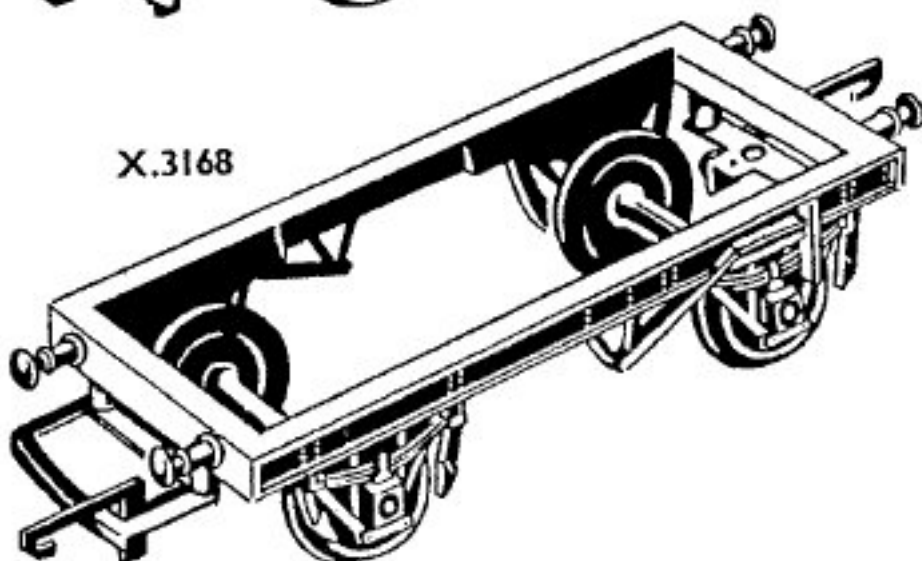

X.329

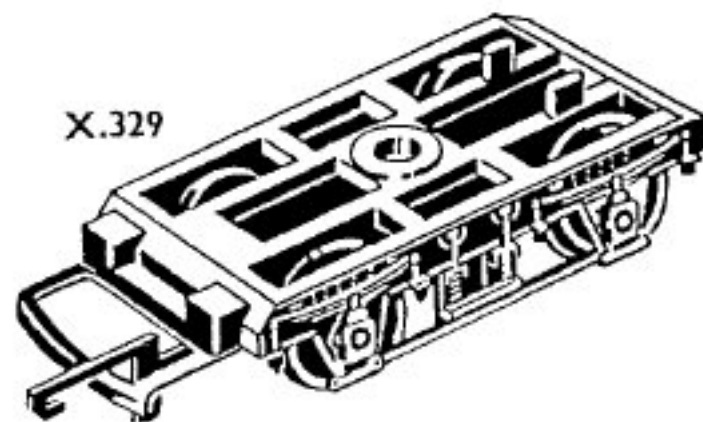

X.330

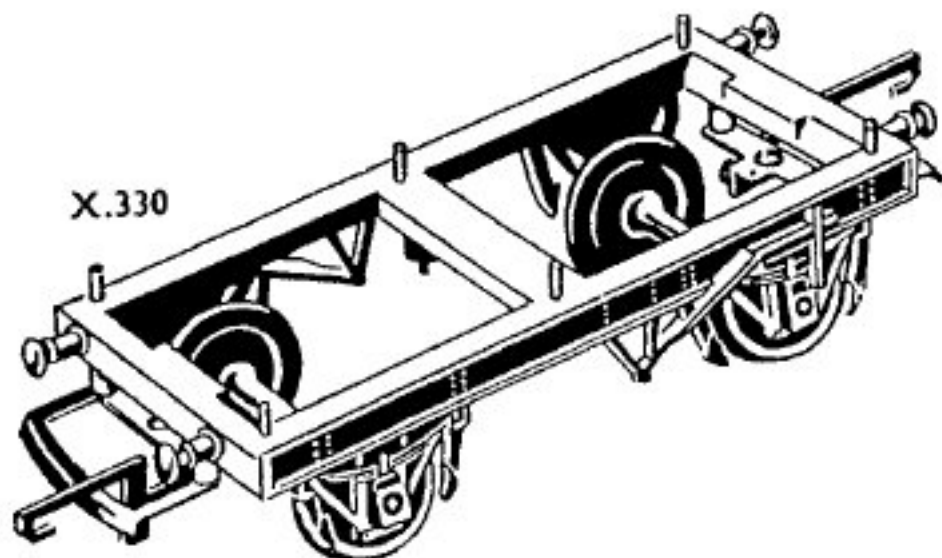

X.3118

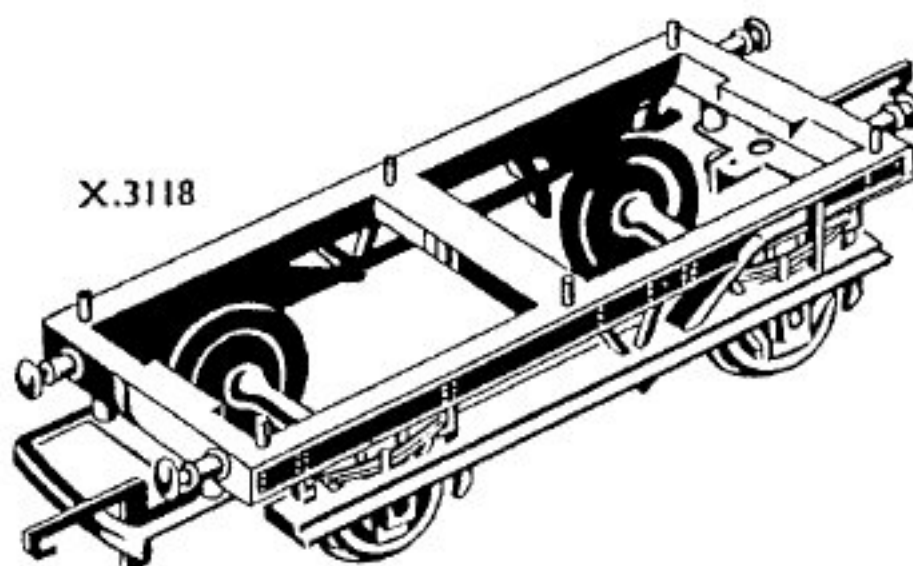

X.305

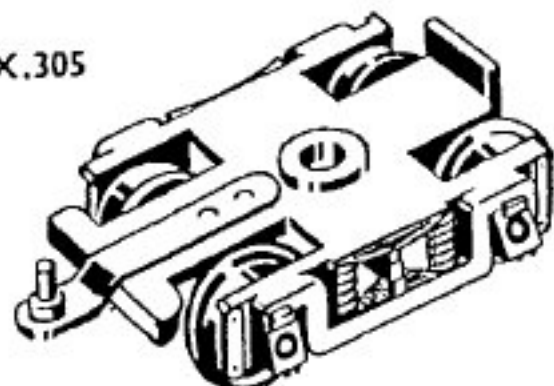

X.307

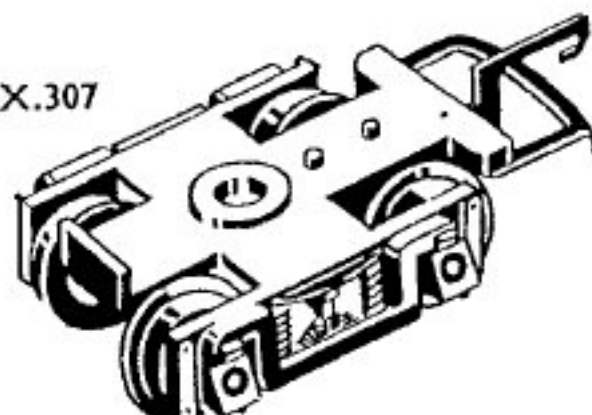

X.304

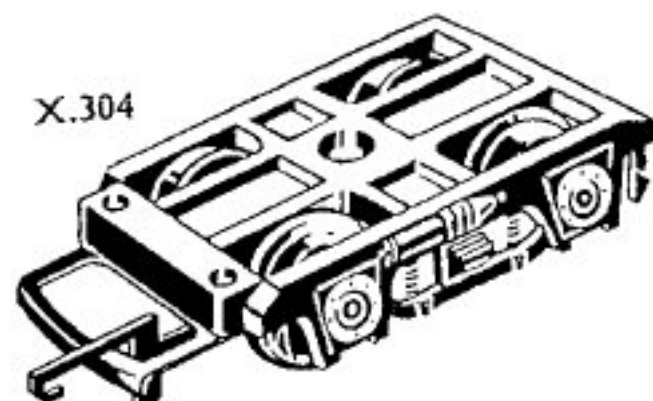

X.302

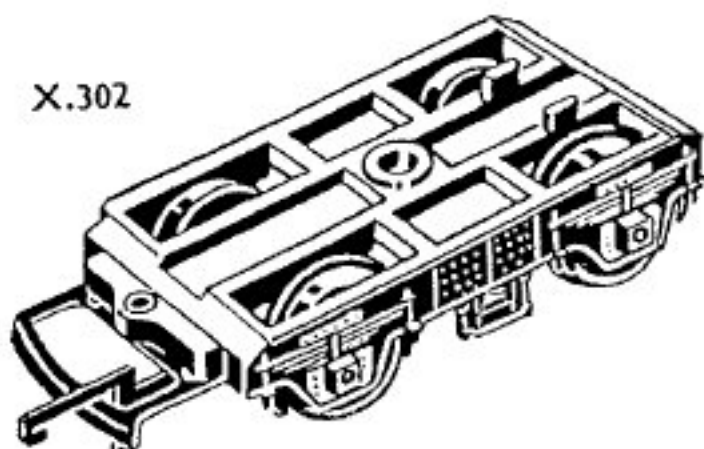

X.303

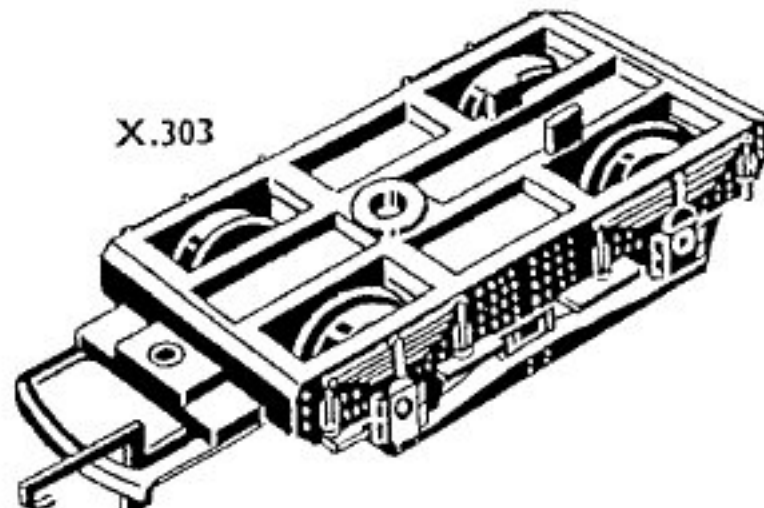

- X.302 Diesel Car Bogie for R.157, R.158
- X.303 Non-powered Motor Bogie for R.225
- X.304 Coach Bogie, T.C. Series
- X.305 Front Bogie for R.32 Tender
- X.307 Rear Bogie for R.32 Tender

- X.310 Coach Bogie, B.R. Type (short)
- X.311 Van and Wagon Chassis (standard)
- X.328 Diamond Frame Bogie
- X.329 Coach Bogie, B.R. Type (long)
- X.330 Van and Wagon Chassis (long wheelbase)

- X.3109 Van Chassis (short wheelbase with running board)
- X.3118 Van Chassis (long wheelbase with running board)
- X.3168 Wagon Chassis (long wheelbase with open centre)

PRINTED IN ENGLAND



**ROVEX SCALE MODELS LIMITED**  
**WESTWOOD, MARGATE, KENT, ENGLAND**  
*A Member of the Lines Bros. Group of Companies*

**SERVICING SHEET**  
**No. 7a**  
*Issued January, 1960*