

## CHASSIS & BOGIE - R.150S

As produced after 1st June, 1964

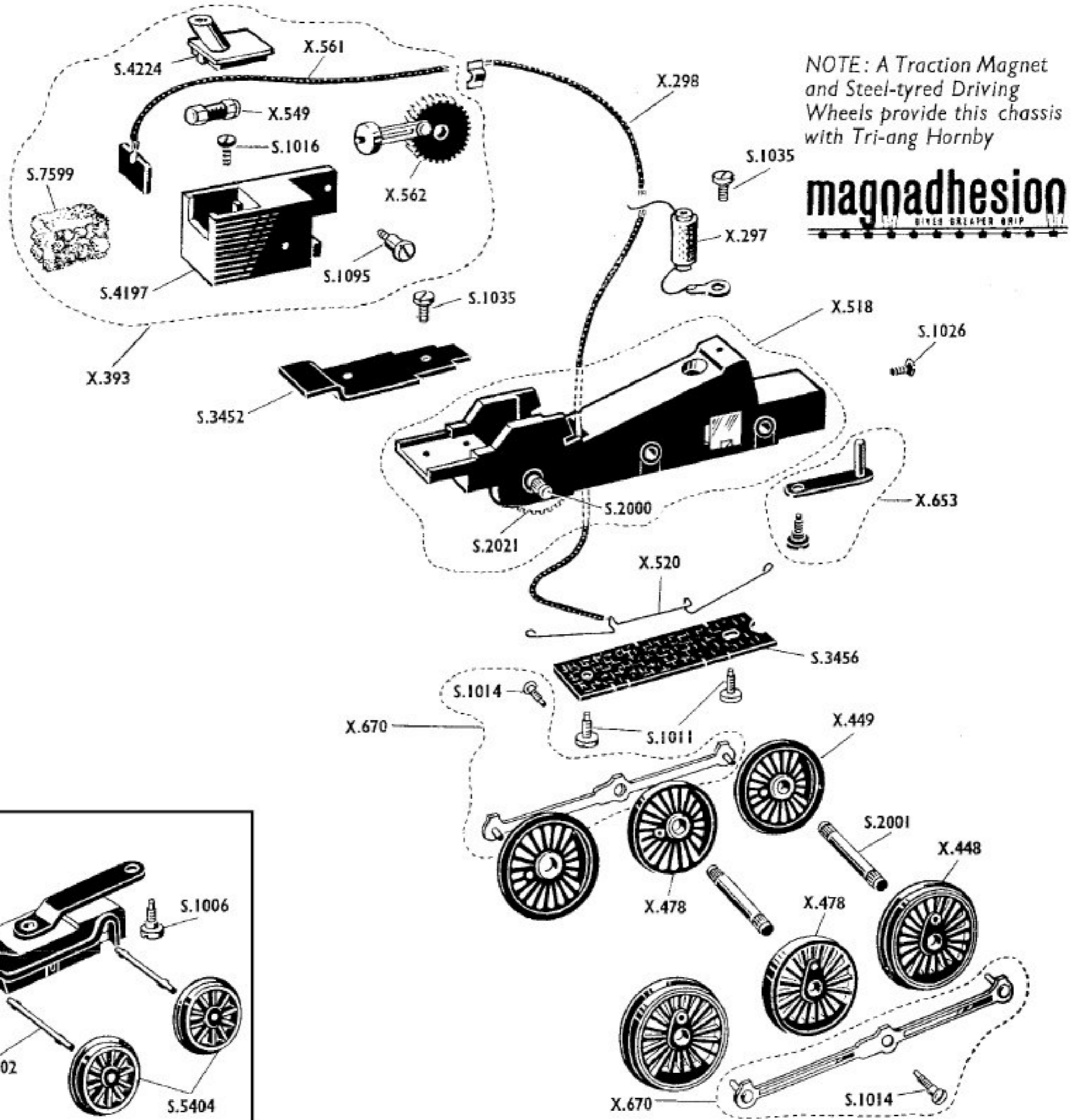

NOTE: A Traction Magnet and Steel-tyred Driving Wheels provide this chassis with Tri-ang Hornby

**magnadhesion**  
BETTER GRIP

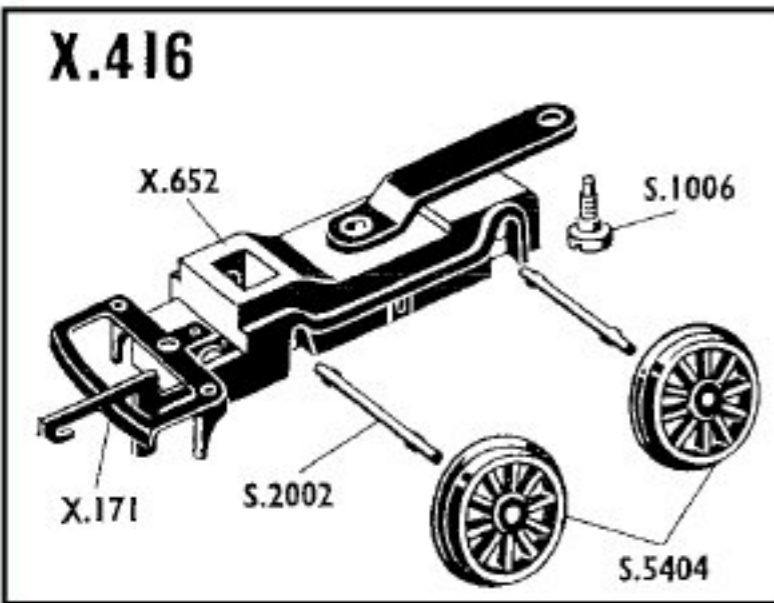

- X.171 Mk. 3 Coupling Unit
- X.297 T.V. Suppressor and Tag Washer
- X.298 Brush Lead and Clip
- X.393 Synchrosmoke Unit Type 3
- X.416 Loco Bogie
- X.448 Flanged Unbushed Driving Wheel
- X.449 Flanged Bushed Driving Wheel
- X.478 Flangeless Bushed Driving Wheel
- X.518 Chassis Assembly
- X.520 Collector Spring and Lead
- X.549 Element

- X.561 Element Contact and Lead
- X.562 Worm Wheel and Piston Assembly
- X.652 Bogie Frame Assembly
- X.653 Drawbar and Screw
- X.670 L/H and R/H Coupling Rods and screws
- S.1006 Bogie Securing Screw
- S.1011 Collector Securing Screw
- S.1014 Coupling Rod Screw
- S.1016 Smoke Unit Securing Screw
- S.1035 Chassis Extension Screw

- S.1026 Body Securing Screw
- S.1095 Pivot Screw
- S.2000 Knurled Driving Axle
- S.2001 Plain Driving Axle
- S.2002 Double Splined Axle
- S.2021 Worm Wheel (40 Teeth)
- S.3452 Chassis Extension
- S.3456 Collector Diaphragm
- S.4197 Smoke Unit Casting
- S.5404 Loco Bogie Wheel
- S.4224 Cover Plate
- S.7599 Fibre Wad

For Motor see Service Sheet No. 51

Modifications are made to Tri-ang Hornby models from time to time. If a spare part is required which does not coincide with the illustration, a full description should be given and, if necessary, a sketch or sample should accompany the order. We do not undertake to supply separate components for the parts listed with an X prefix, unless a separate S part number is shown.