

0-6-0 LOCOMOTIVE CHASSIS

As produced from mid 1987
(British Patent Application
Serial No. 2176124)

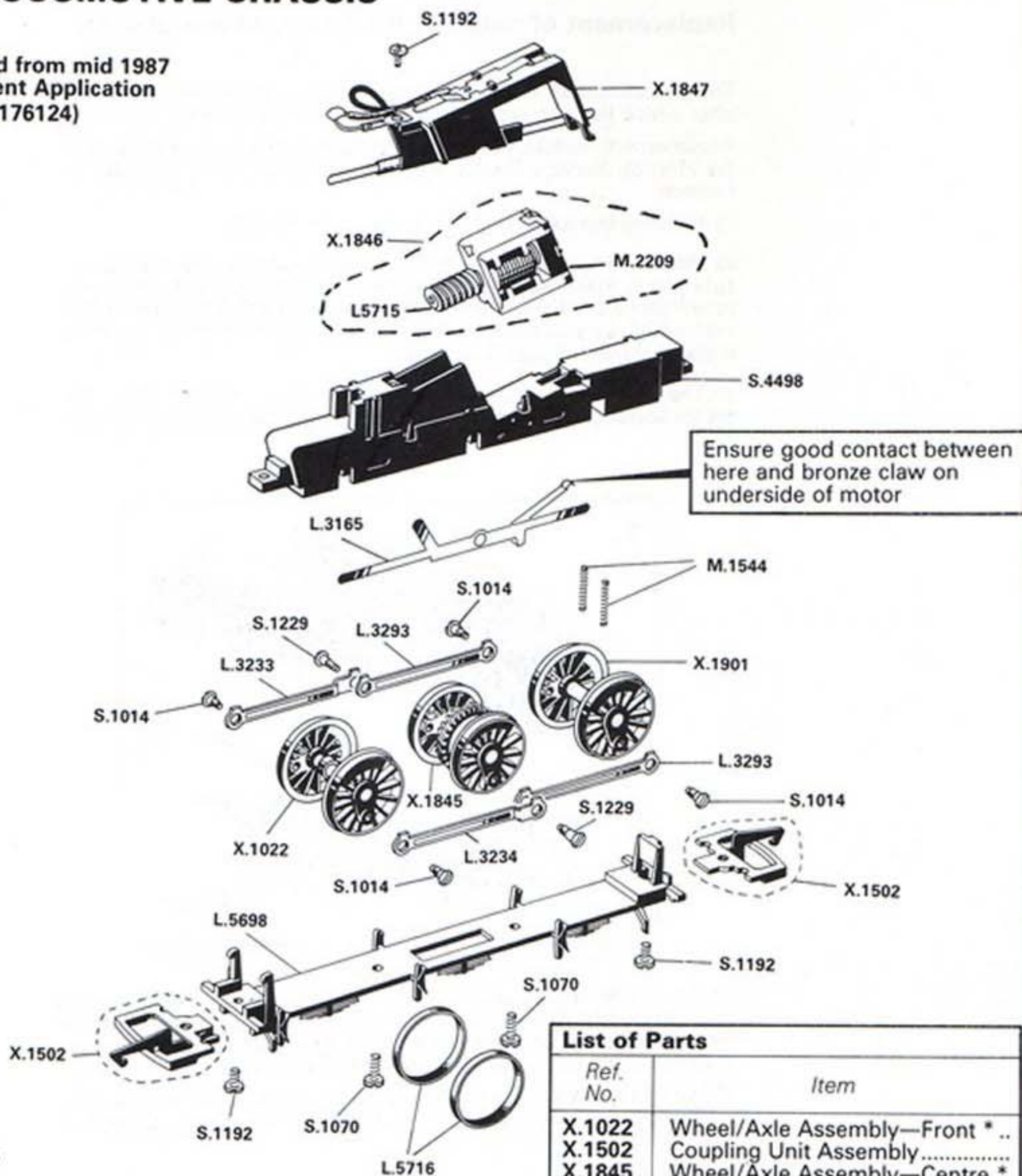

The chassis is designed to provide a strong hauling locomotive with good electric pick-up and low weight.

A balance has to be struck between the strength of the coil springs holding the rear driving axle down (and thus lifting the centre wheels off the track) and the body weights which compress the springs and keep the traction tyred centre wheels in contact with the track. The chassis cannot be performance tested without the body in place.

The spring pressure may be reduced by snipping off one turn from each spring. It may be increased by inserting discs of paper or cardboard, 2mm. in diameter, into the spring holes before refitting the springs.

Ref. No.	Item
X.1022	Wheel/Axle Assembly—Front * ..
X.1502	Coupling Unit Assembly.....
X.1845	Wheel/Axle Assembly—Centre *
X.1846	Motor with Worm Gear
X.1847	Motor Retaining Assembly.....
X.1901	Wheel/Axle Assembly—Rear * ...
L.3165	Pick-up Terminal.....
L.3233	Coupling Rod *
L.3234	Coupling Rod *
L.3293	Coupling Rod *
L.5698	Chassis bottom.....
L.5715	Worm Gear
L.5716	Traction Tyre
M.1544	Spring
M.2209	Motor only.....
S.1014	Screw—Coupling Rod.....
S.1070	Screw—Chassis.....
S.1192	Screw—Chassis.....
S.1229	Screw—Coupling Rod.....
S.4498	Chassis

* State colour required.

Replacement of motor in 0-6-0 Locomotive chassis

The electric motor has a running life of approximately 500 hours after which the non-replaceable 'brushes' may become worn out. Replacement motors, complete with worm gears are available from the Hornby Service Centre, Part No. X. 1846. To fit, proceed as follows.

- 1) Remove the locomotive body from the chassis.
- 2) Undo and remove screw **A** on top of chassis (Fig. 1) and keep in a safe place. Insert screwdriver blade into position from which the screw came and lever motor housing assembly **B** (Fig. 2) (complete with wiring harness and long bronze collector arm) upwards, pivoting it about the small lugs **C** at its rear.
- 3) The electric motor, with worm gear fitted, unclips from the motor housing assembly by gently stretching the rear bearing boss.

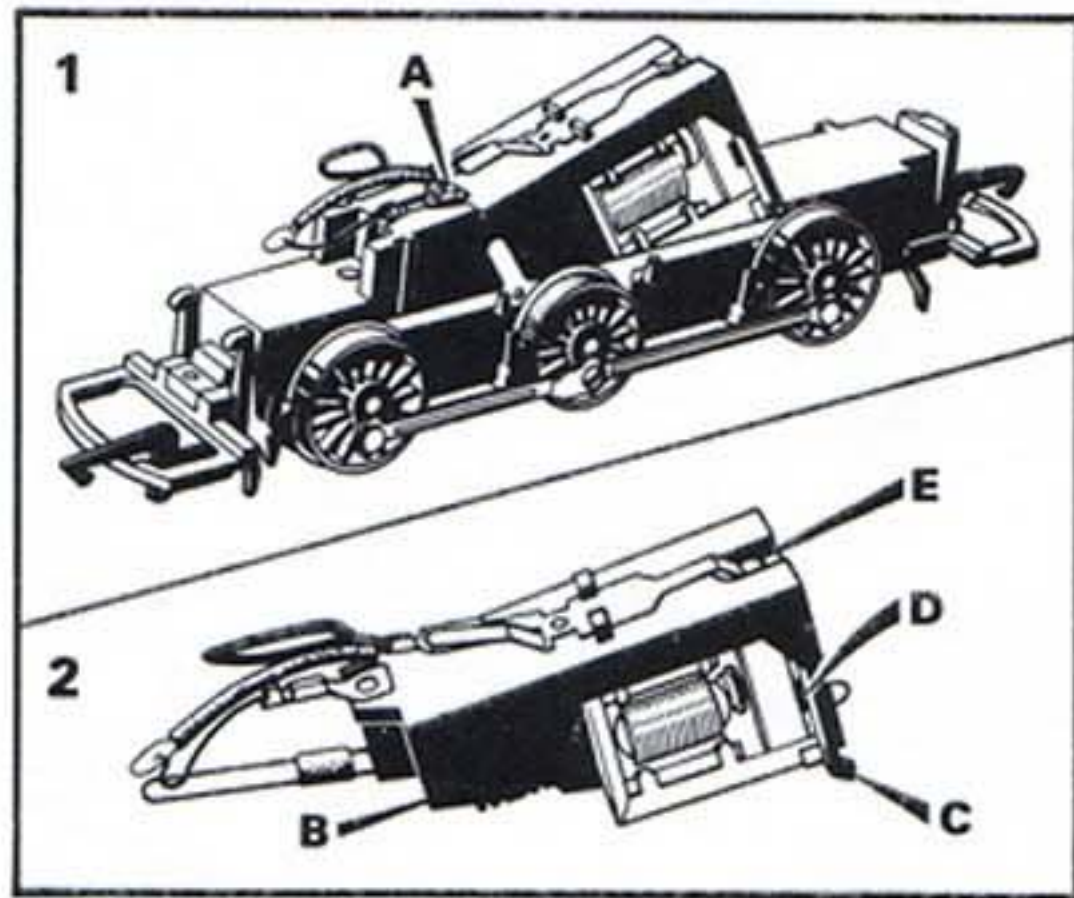

4) Before fitting the replacement motor into the housing, note that there is a small indentation **D** in the plastic on one side of the motor rear bearing block. The motor must be inserted into the housing so that this indentation will be on the LEFT side of the locomotive.

When the replacement motor has been clipped into the housing, ease the tip of the bronze claw **E** so that it overlaps the small contact sticking up from the motor.

5) Refit housing to chassis. Insert lugs **C** first and then gently push down front end making sure that the ends of the long bronze collector arm are tucked inside the wheels. Replace the screw, catching in the tag washer. This must be done accurately as its tightness controls the meshing of the gears.

Check that the collector arm extremities are bearing on the inside faces of the wheels.

6) Test out the chassis before refitting the body.